

GD350-01H Series

VFD for High-speed Motor

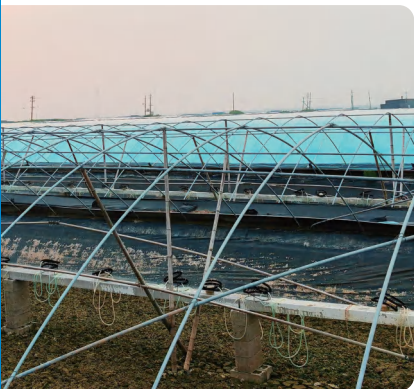

CONTENT

Company Introduction	01
Product features	02
Smart chip and smart control	03
Reliability and ease of use	04
Function expansion	07
Intelligent connectivity	08
Host controller commissioning	09
Technical specifications	10
Product specifications	11
Control circuit	13
Product dimensions	15
Accessory selection	22

The **GD350-01H series** VFD is a high-speed driver specially upgraded based on industry application requirements, focusing on permanent magnet synchronous motor control. It adopts the Euler control platform technology, which employs modular and layered design concepts, with deep optimizations in multiple aspects including software architecture, vector control algorithms, parameter autotuning, and rectifier harmonic suppression algorithms, thereby enhancing its reliability, stability, adaptability, and ease of use. With industry-specific functions and interfaces, the VFD offers a wide range of expansion features, meeting the requirements for specialized applications and diversified solutions, and delivering comprehensive solutions.

Power range:

AC 3PH 220V(-15%)~240V(+10%): 7.5~185kW

AC 3PH 380V(-15%)~440V(+10%): 7.5~500kW

AC 3PH 520V(-15%)~690V(+10%): 22~630kW



Industry-specific Equipment:

Magnetic bearing
turbo vacuum pump

Air suspension
blower

High-speed
turbo blower

High-speed
aerator

Magnetic bearing
refrigeration compressor

High-speed centrifugal
air compressor

Magnetic bearing
turbo blower

ABOUT US



INVT (Shenzhen INVT Electric Co., Ltd) has been concentrating on industry automation and energy power since its foundation in 2002 and is committed to "Providing the best product and service to allow customers more competitiveness". INVT goes public in 2010 and is the first A-share listed company (002334) in Shenzhen Stock Exchange in the industry. At present, INVT owns 15 subsidiaries and more than 4500 employees, over 40 branches, forming a sales network covering more than 100 overseas countries and regions.

INVT has been awarded as the Key High-tech Enterprise of National Torch Plan based on mastering of key technologies in power electronics, auto control and IT. With business covering industry automation, electric vehicle, network power and rail transit, INVT has established 10 R&D centers nationwide, boasts more than 1400 patents and owns the first lab in the industry awarded ACT qualification from TÜV SÜD, UL-WTDP and CNAS National Lab. The industrial parks in Shenzhen and Suzhou aim to provide customers with advanced integrated product development design management, comprehensive product R&D test and auto informational production. The worldwide INVT branches and warranty service centers are ready to offer customers all-around back-ups including professional solutions, technical trainings and service support.

In the next decade, INVT will continue to take " Sincere Virtuous, Professional Aspiring" as our business philosophy, enhance core business sectors including industrial automation, electric vehicle, network power and rail transit based on the three major technologies in industry automation and energy power fields, and strive to become a leading, responsible and harmonic international professional group armed with proper product structure, leading technologies, efficient management, robust profitability and superior competitiveness.



Product features >>>

The "Euler control platform" algorithm is employed to optimize the design with the goal of improving the performance of synchronous motors in areas such as low harmonic control, flux weakening control, parameter adaptation, and motor protection.

The output frequency supports up to **1200Hz**.
Carrier frequency $\leq 15\text{kHz}$



Smart chip and smart control

"Euler" control algorithm

- ✓ Multiple control modes (V/F, vector, VVC+), adaptable to different types of motor loads
- ✓ Supports three-phase modulation and two-phase modulation modes
- ✓ One-click parameter autotuning with no need for loop tuning, simplifying the commissioning process
- ✓ Harmonic reduction solution: VVC+ algorithm/LC harmonic suppression scheme, with output current harmonics $\leq 3\%$
- ✓ Supports multiple motor types: asynchronous motors and permanent magnet synchronous motors
- ✓ Supports energy-saving control algorithms to improve energy efficiency

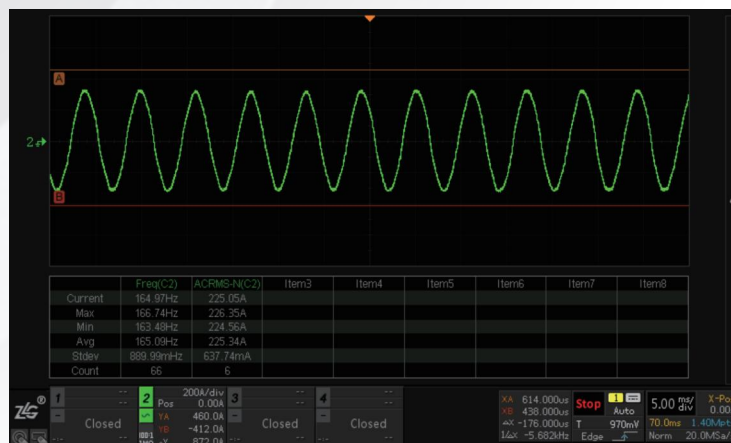
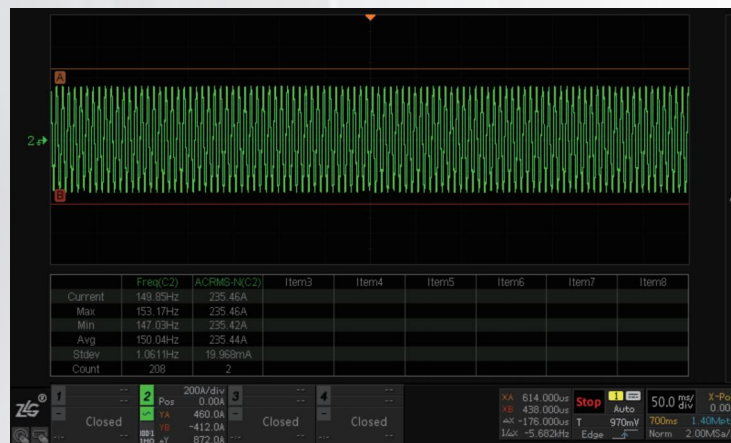

Reliability and ease of use

Industry-specific interfaces

- Dedicated interfaces are provided, including integrated PT100 and pressure input, with pluggable terminal design for high wiring efficiency and convenient maintenance.

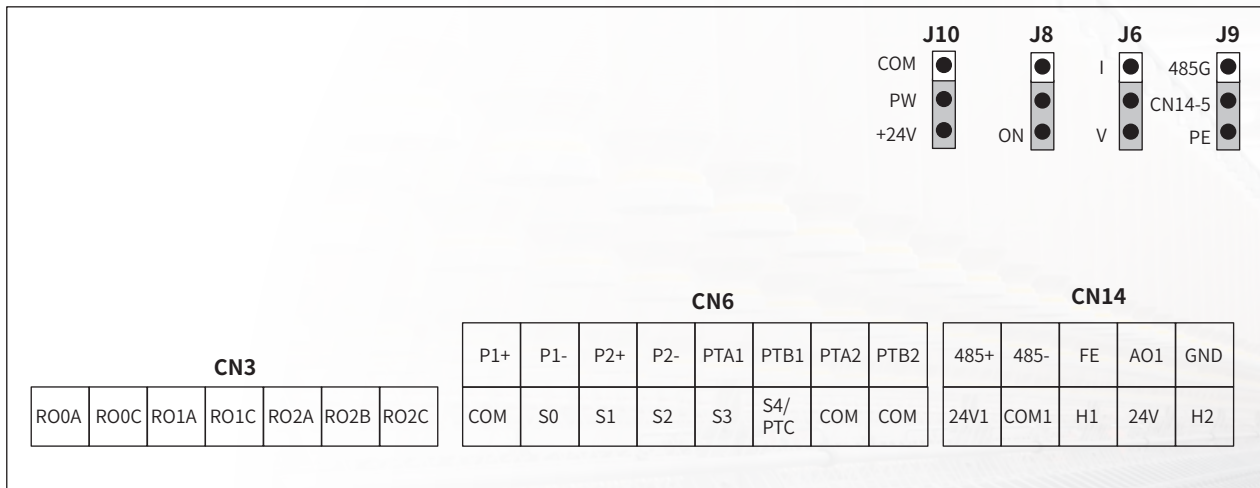

Power-off self-generation function

- In the event of a power outage, the VFD can supply power to the magnetic bearing controller through its self-generation function, ensuring a smooth shutdown of the magnetic bearings.

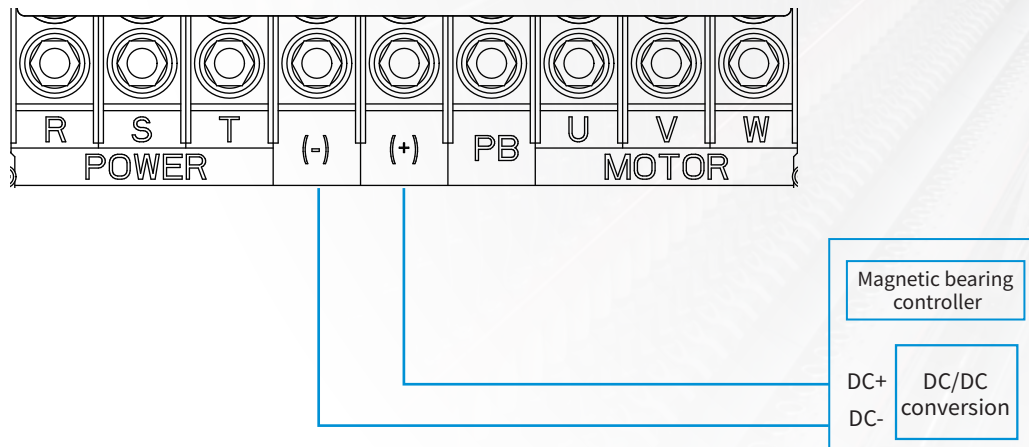

Highly reliable cooling fan

- ◆ The cooling fan uses an IP55 high-protection vacuum coating process to extend its service life.

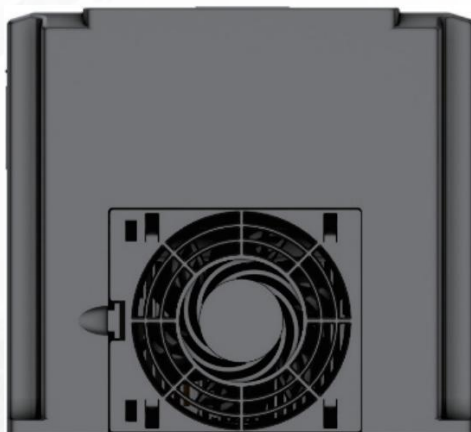

Keypad

- ◆ Supports batch parameter copying and commissioning, saving time and minimizing parameter setting errors
- ◆ LCD keypad with intuitive display for easy commissioning

* LCD keypad ordering code: 11022-00225 (KEY-LCD03-ZY-GD350-01H)



LED large keypad (standard)



LCD keypad (optional)



24V power output for external devices

- ◆ Provides a 24V/1A power output for devices such as touch screens and IoT modules, eliminating the need for an external power supply and simplifying the control cabinet layout.



STO function

- ◆ Standard Safe Torque Off (STO) function, compliant with IEC 61508, IEC 61800-5-2, IEC 62061, and ISO 13849-1 standards
- ◆ Function: The STO function turns off the drive output by shutting down the drive signal, cutting off the electrical power supply to the motor, and thereby stopping torque output. When STO is activated and the motor is at standstill, this function prevents any unintended motor start-up.

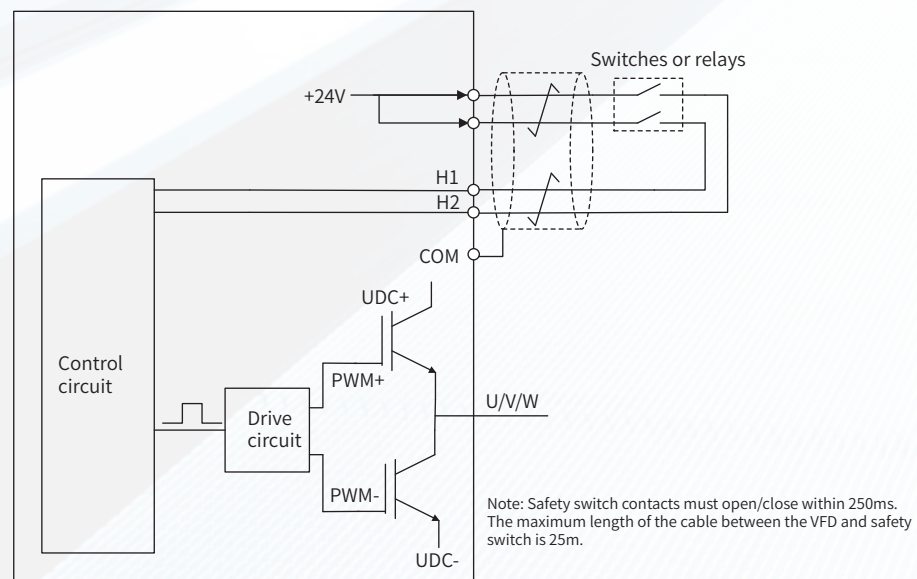

Function expansion

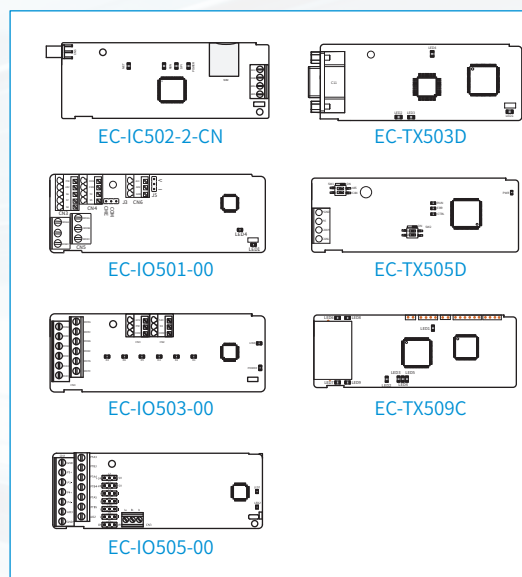

- ◆ Communication: Standard RS485 communication with isolation, supporting communication expansions such as PROFIBUS-DP, CAN, and PROFINET
- ◆ I/O and analog: Supports expansion of digital inputs/outputs, relay outputs, analog inputs/outputs, PT100 temperature detection, and other interfaces

Expansion card type	Expansion card model	Expansion card slot compatibility
IO expansion card 1	EC-IO501-00	SLOT1 and SLOT2 are both supported
IO expansion card 3	EC-IO503-00	SLOT1 and SLOT2 are both supported
IO expansion card 5	EC-IO505-00	SLOT1 and SLOT2 are both supported
PROFIBUS-DP communication card	EC-TX503D	SLOT1 is recommended
CAN multi-protocol communication card	EC-TX505D	SLOT1 and SLOT2 are both supported
PROFINET communication card	EC-TX509C	SLOT1 and SLOT2 are both supported
IoT 4G expansion card	EC-IC502-2-CN	SLOT2 is recommended

- When using the PROFIBUS-DP communication card and the IoT 4G module simultaneously, please install them according to the recommended slots in the table above. Otherwise, structural interference may occur, affecting functionality.
- Models of 22kW and below do not support the installation and use of the PROFIBUS-DP communication card.

*For details of the expansion card, see the product manual.

Intelligent connectivity

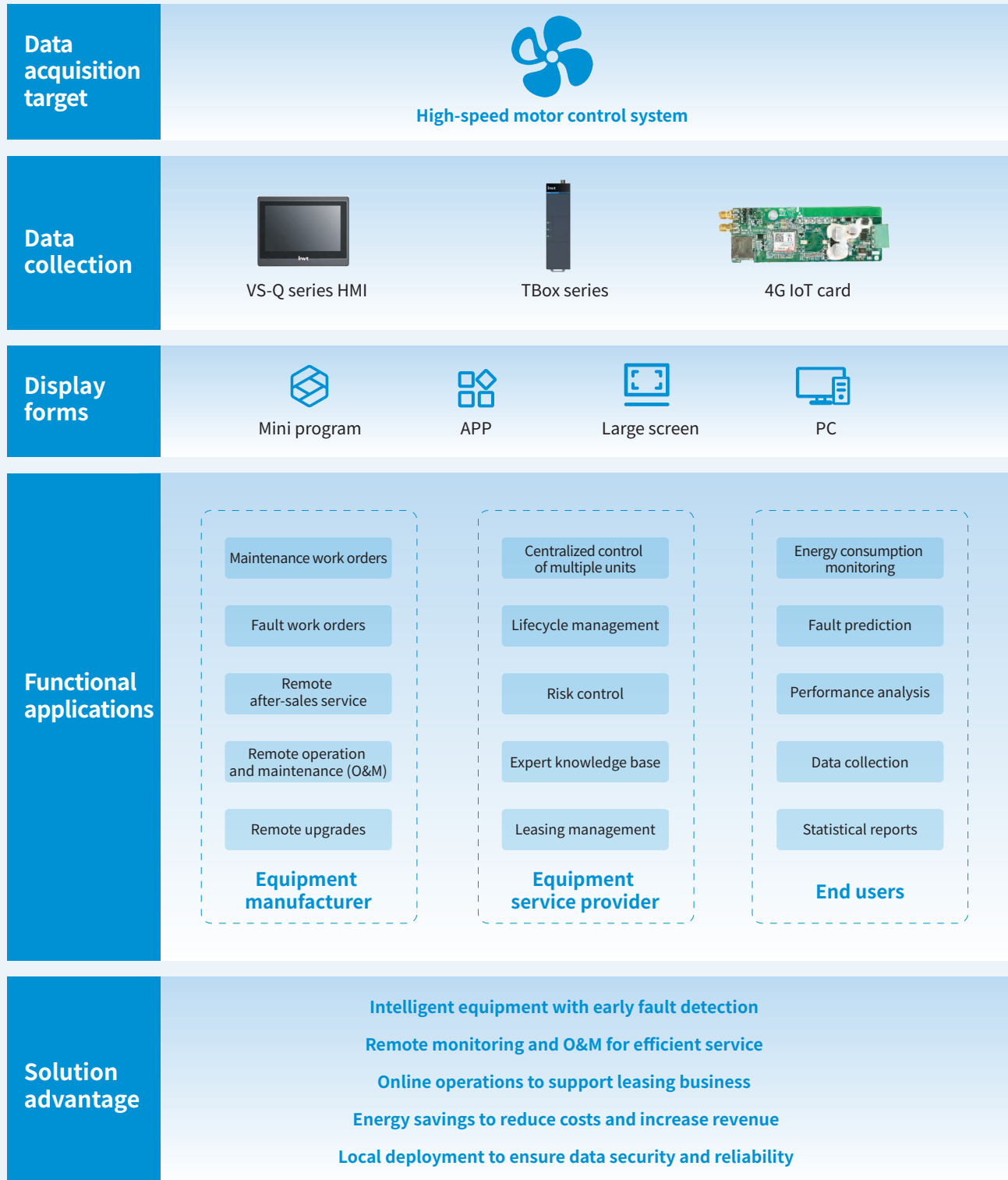

Host controller commissioning

The INVT Workshop software is used to configure and monitor the VFD, and can monitor multiple VFDs simultaneously.

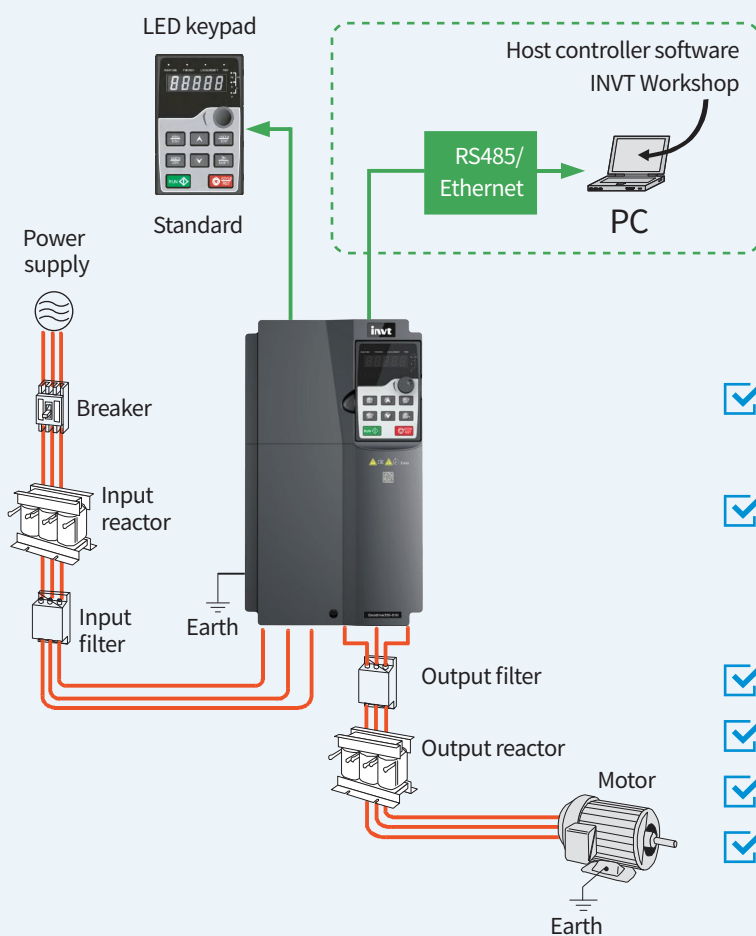

- ✓ Set and monitor function code parameters, and upload and download parameters in batch
- ✓ View the modified function codes, compare the default values, follow function codes, and search function codes
- ✓ View and follow state parameters
- ✓ View the real-time faults and historical faults
- ✓ Display function codes in configuration mode
- ✓ Control the start/stop and forward/reverse running of the device
- ✓ View oscilloscope curve, save and playback waveform data, operate the waveform by cursor, and simulate waveform data

**Please visit www.invt.com to obtain it for free.*

Technical specifications >>>

Item		Specifications
Power input	Input voltage (V)	Rated voltage: 220V Voltage range: AC 3PH 220V(-15%)–240V(+10%) Rated voltage: 380V Voltage range: AC 3PH 380V(-15%)–440V(+10%) Rated voltage: 660V Voltage range: AC 3PH 520V(-15%)–690V(+10%)
	Allowed voltage transient fluctuation	-15%~+10%
	Input current (A)	Refer to the product ratings for the corresponding power
	Input frequency (Hz)	50Hz or 60Hz; allowed range: 47–63Hz
Power output	Output voltage (V)	0~Input voltage
	Output current (A)	Refer to the product ratings for the corresponding power
	Output frequency (Hz)	0~400Hz (AC 3PH 660V voltage input) 0~1200Hz
Running control performance	Control mode	Space voltage vector control, and sensorless vector control (SVC)
	Motor type	Asynchronous motor (AM) and permanent magnet synchronous motor (SM)
	Speed ratio	For asynchronous motor (AM), 1:100 (SVC); for synchronous motor (SM), 1:20 (SVC)
	Speed control accuracy	±0.2% (SVC)
	Speed fluctuation	±0.3% (SVC)
	Torque response	<20ms (SVC)
	Torque control accuracy	10% (SVC)
	Starting torque	For AMs: 0.25Hz/150% (SVC) For SMs: 2.5Hz/150% (SVC)
	Frequency setting method	Settings can be implemented through digital, analog, multi-step speed run, PID, and Modbus communication. Settings can be combined and the setting channels can be switched.
Fault protection	More than 30 protection functions, such as protection against overcurrent, overvoltage, undervoltage, overtemperature, phase loss, and overload.	
Other	Mounting method	Supports wall mounting, floor mounting, and flange mounting.
	Temperature of running environment	-10~+50°C For 7.5–200kW models, derating is required when the ambient temperature exceeds 45° C; for 220–500kW models, derating is required when the ambient temperature exceeds 40° C. Derate 1% for every increase of 1° C.
	Ingress protection (IP) rating	IP20
	Cooling method	Forced air cooling

Product specifications >>>

Product model	Output power (kW)	Input current (A)	Output current (A)
AC 3PH 380V(-15%)~440V(+10%) single unit			
GD350-01H-7R5G-4	7.5	25	18.5
GD350-01H-011G-4	11	32	25
GD350-01H-015G-4-L1	15	32	32
GD350-01H-018G-4-L1	18.5	37	38
GD350-01H-022G-4-L1	22	44	45
GD350-01H-030G-4-L1	30	58	60
GD350-01H-037G-4-L1	37	72	75
GD350-01H-045G-4-L1	45	101	92
GD350-01H-055G-4-L1	55	117	115
GD350-01H-075G-4-L1	75	140	150
GD350-01H-090G-4-L1	90	170	180
GD350-01H-110G-4-L1	110	202	215
GD350-01H-132G-4	132	265	260
GD350-01H-160G-4	160	310	305
GD350-01H-185G-4	185	345	340
GD350-01H-200G-4	200	385	380
GD350-01H-220G-4	220	430	425
GD350-01H-250G-4	250	485	480
GD350-01H-280G-4	280	545	530
GD350-01H-315G-4	315	610	600
GD350-01H-355G-4	355	625	650
GD350-01H-400G-4	400	715	720
GD350-01H-450G-4	450	840	820
GD350-01H-500G-4	500	890	860
AC 3PH 520V(-15%)~690V(+10%) single unit			
GD350-01H-022G-6	22	35	27
GD350-01H-030G-6	30	40	35
GD350-01H-037G-6	37	47	45
GD350-01H-045G-6	45	52	52
GD350-01H-055G-6	55	65	62
GD350-01H-075G-6	75	85	86
GD350-01H-090G-6	90	95	98

Product model	Output power (kW)	Input current (A)	Output current (A)
AC 3PH 520V(-15%)~690V(+10%) single unit			
GD350-01H-110G-6	110	118	120
GD350-01H-132G-6	132	145	150
GD350-01H-160G-6	160	165	175
GD350-01H-185G-6	185	190	200
GD350-01H-200G-6	200	210	220
GD350-01H-220G-6	220	230	240
GD350-01H-250G-6	250	255	270
GD350-01H-280G-6	280	286	300
GD350-01H-315G-6	315	334	350
GD350-01H-355G-6	355	360	380
GD350-01H-400G-6	400	411	430
GD350-01H-450G-6	450	445	465
GD350-01H-500G-6	500	518	540
GD350-01H-560G-6	560	578	600
GD350-01H-630G-6	630	655	680
AC 3PH 220V(-15%)~240V(+10%)			
GD350-01H-3R7G-2	3.7	25	18.5
GD350-01H-5R5G-2	5.5	32	25
GD350-01H-7R5G-2- L1	7.5	32	32
GD350-01H-011G-2- L1	11	44	45
GD350-01H-015G-2- L1	15	58	60
GD350-01H-018G-2- L1	18	72	75
GD350-01H-022G-2- L1	22	101	92
GD350-01H-030G-2- L1	30	117	115
GD350-01H-037G-2- L1	37	140	150
GD350-01H-045G-2- L1	45	170	180
GD350-01H-055G-2- L1	55	202	215
GD350-01H-075G-2	75	265	260
GD350-01H-090G-2	90	345	340
GD350-01H-110G-2	110	385	380
GD350-01H-132G-2	132	485	480
GD350-01H-160G-2	160	545	530
GD350-01H-185G-2	185	625	650
GD350-01H-200G-2	200	715	720
GD350-01H-220G-2	220	840	820
GD350-01H-250G-2	250	890	860

Control circuit

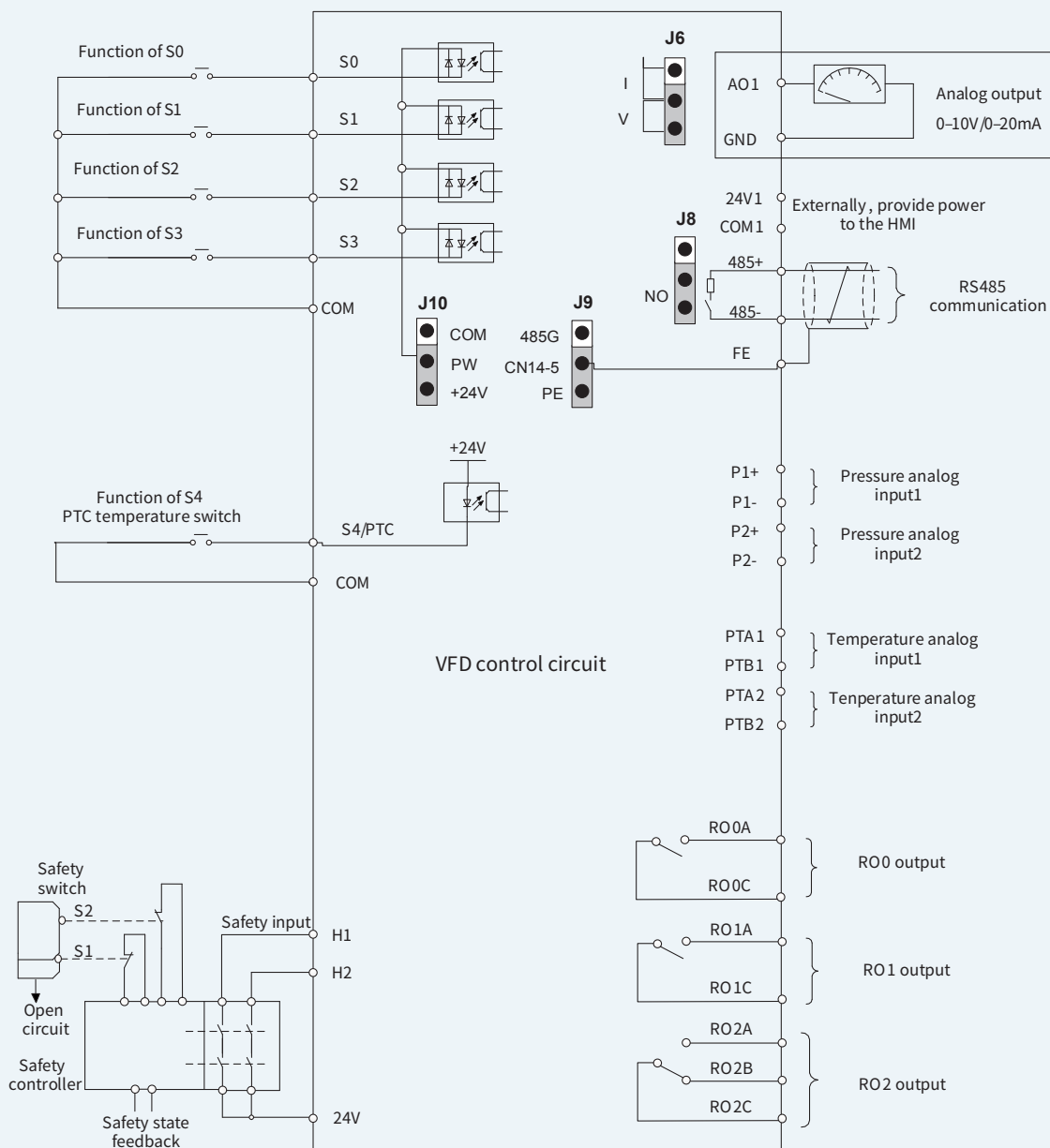

Terminal	Description
RO0A	Relay outputs. RO0A: NO; RO0C: common Contact capacity: 3A/250VAC, 1A/30VDC
RO0C	
RO1A	Relay output. RO1A: NO; RO1C: common Contact capacity: 3A/250VAC, 1A/30VDC
RO1C	
RO2A	Relay output. RO2A: NO; RO2B: NC; RO2C: common Contact capacity: 3A/250VAC, 1A/DC30V
RO2B	
RO2C	
P1+	1.Input range: Current and voltage are available for selection, 0–20mA/0–10V; P1 is switched through the function code P05.33 while P2 through the function code P05.34.
P1-	
P2+	
P2-	
PTA1	1.Resolution: 1° C 2.Range: -40°C –+200° C 3.Detection precision: 3° C
PTB1	
PTA2	
PTB2	
COM	Reference ground of PCB internal power +24V
S0	Digital input
S1	
S2	
S3	
S4/PTC	Digital input S4, only supporting internal 24V power supply (NPN mode) External PTC temperature switch signal input. It acts when the PTC resistance reaches 2.6kΩ.
485+	RS485 differential signal communication port. The standard RS485 communication interface should use shielded twisted pair.
485-	
FE	Function ground wiring terminal
AO1	1.Output range: 0–10V/0–20mA. You can choose voltage or current output through J6. The default output type is voltage. 2.Error: ±1% at 25° C
GND	
24V1	Used to externally provide DC power supply. Rated output voltage: 24V, and max. output current: 1000mA.
COM1	
24V–H1	Safe torque off (STO) inputs
24V–H2	

Product dimensions



Wall-mounted installation dimensions

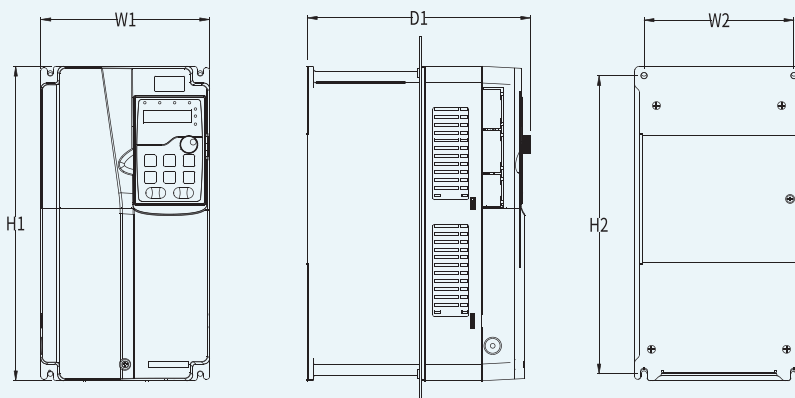

Outline and wall mounting dimensions of 380V 7.5-37kW VFD models

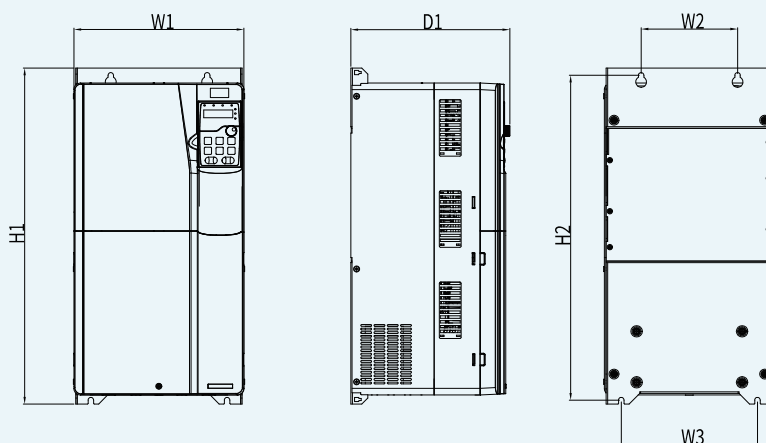

Outline and wall mounting dimensions of 380V 45-55kW VFD models

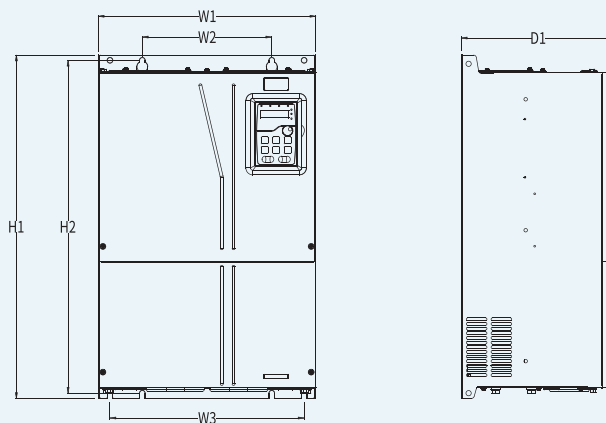

Outline and wall mounting dimensions of 380V 75kW VFD models

Wall-mounted installation dimensions

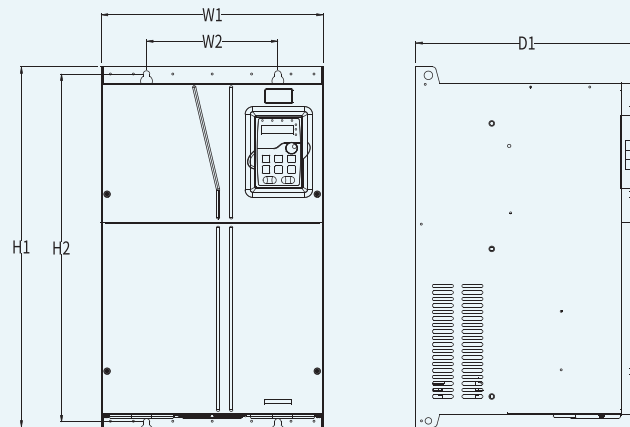

Outline and wall mounting dimensions of 380V 90-110kW VFD models

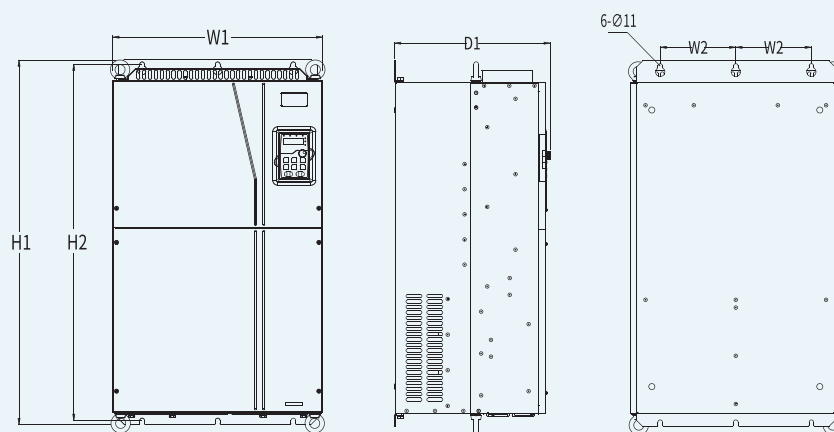

Outline and wall mounting dimensions of 380V 132-200kW VFD models

Wall-mounted installation dimensions

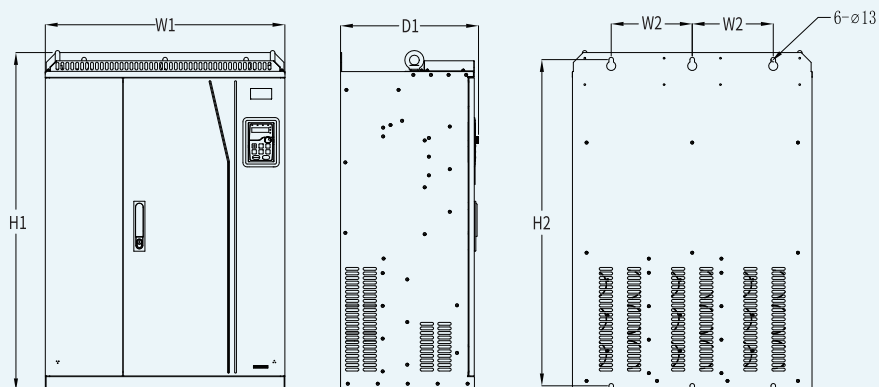

Outline and wall mounting dimensions of 380V 220~315kW VFD models

VFD power	Outline dimensions (mm)			Mounting hole distance (mm)			Hole diameter (mm)	Fixing screw
	W1	H1	D1	H2	W2	W3		
7.5kW	170	320	225	304	151	-	Ø 6	M5
11~22kW	200	341	212	329	185	-	Ø 6	M5
30~37kW	250	400	227	380	230	-	Ø 6	M5
45~55kW	282	560	264	542	160	226	Ø 9	M8
75kW	370	590	270	572	220	330	Ø 9	M8
90~110kW	338	554	338	535	200	-	Ø 10	M8
132~200kW	500	872	371	850	180	-	Ø 11	M10
220~315kW	680	960	392	926	230	-	Ø 13	M12
355kW	680	960	392	926	213	163.5	Ø 13	M12

Floor mounting dimensions

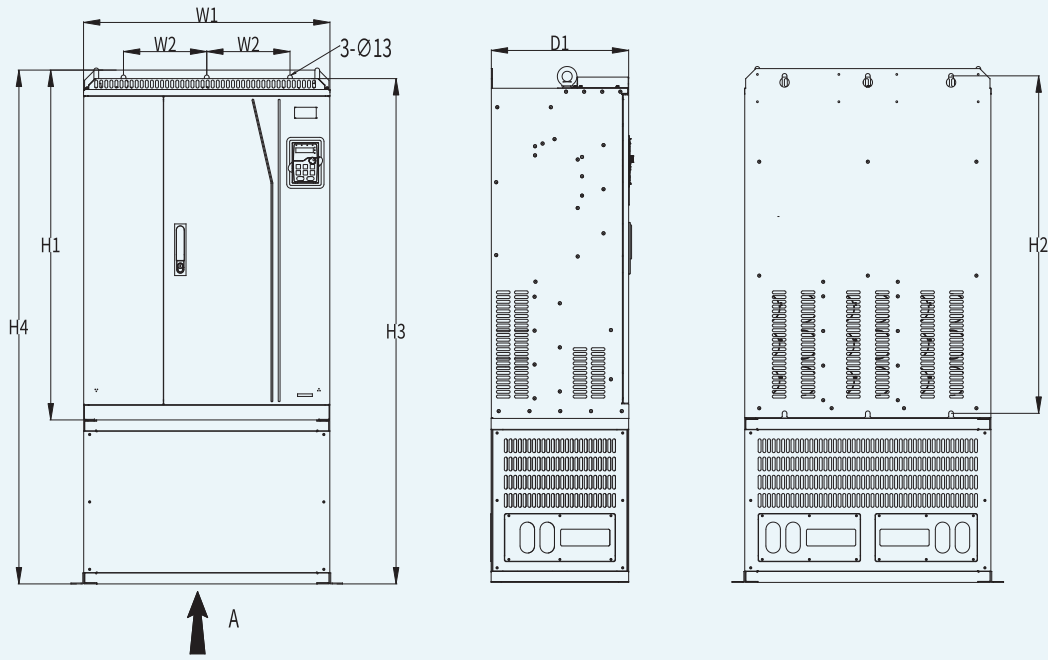

View A

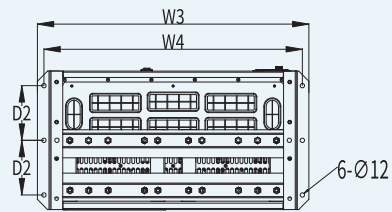

Outline and floor mounting dimensions of 380V 220~315kW VFD models

Floor mounting dimensions

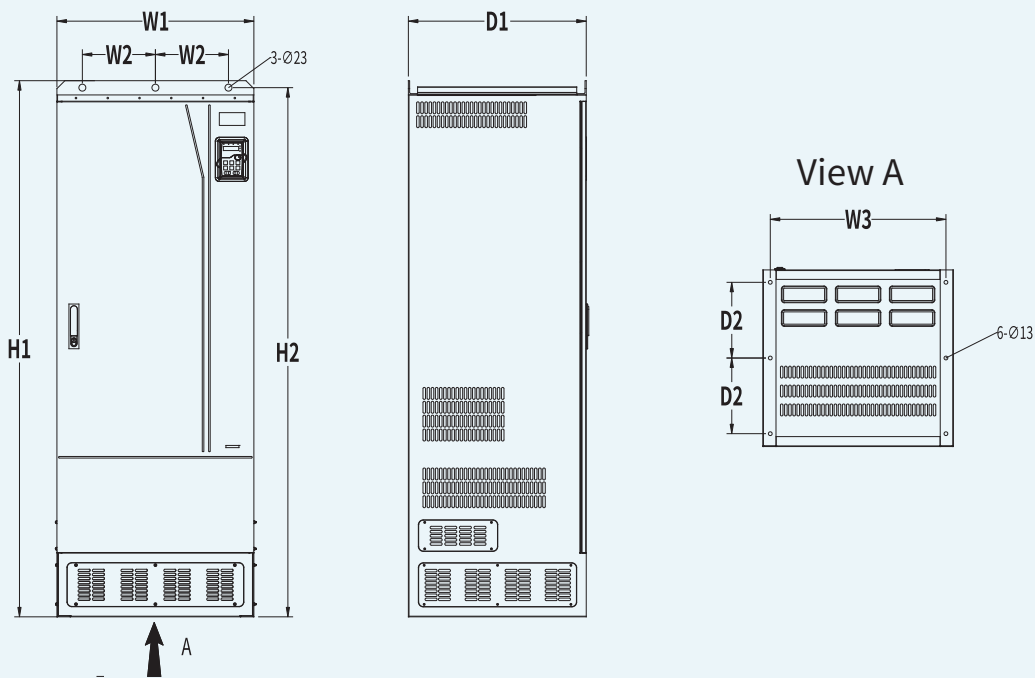

Outline and floor mounting dimensions of 380V 355~500kW VFD models

VFD power	Outline dimensions (mm)			Mounting hole distance (mm)				Hole diameter (mm)	Fixing screw	
	W1	W4	H1	D1	H2	W2	W3			D2
220~315kW	680	750	1410	392	1390	230	714	150	Ø 13/Ø12	M12/M10
355~500kW	620	-	1700	572	1678	230	572	240	Ø 22/ Ø12	M12/M10

Flange mounting dimensions

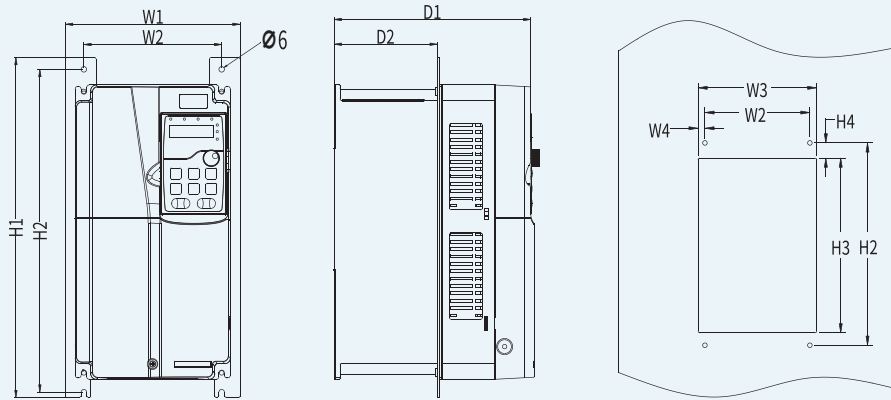

Flange mounting dimensions and hole positions for 380V 7.5-55kW VFDs

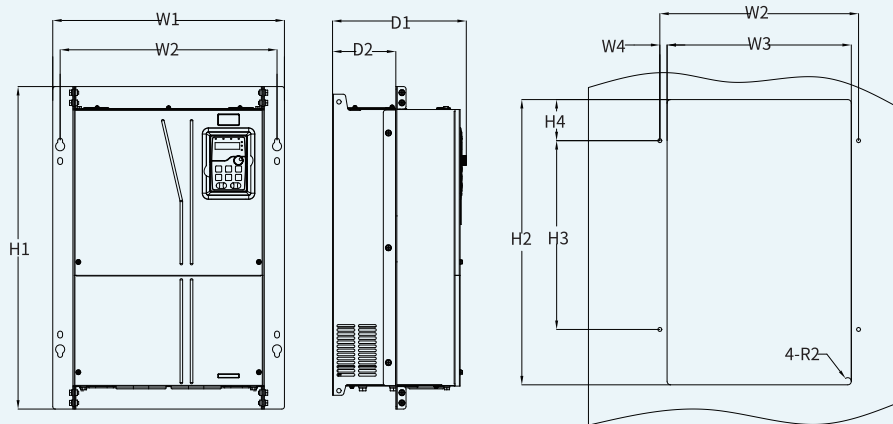

Flange mounting dimensions and hole positions for 380V 75-110kW VFDs

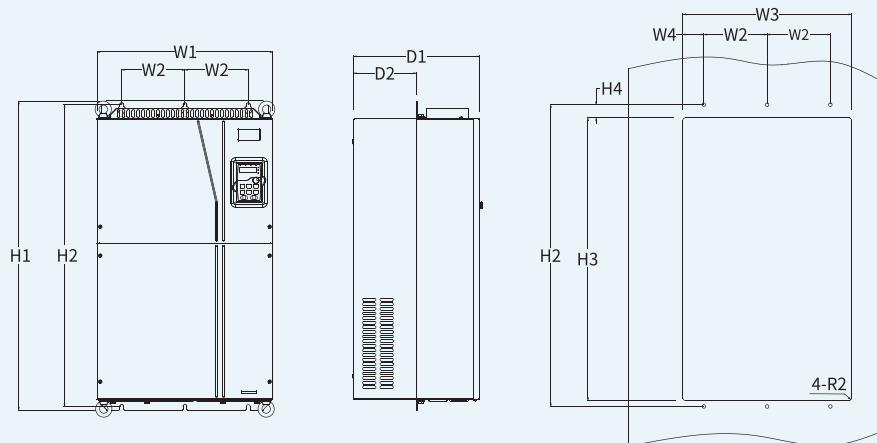

Flange mounting dimensions and hole positions for 380V 132-200kW VFDs

VFD power	Outline dimensions (mm)				Mounting hole distance (mm)						Hole diameter (mm)	Fixing screw
	W1	W2	W3	W4	H1	H2	H3	H4	D1	D2		
7.5kW	191.2	151	174	11.5	370	351	324	12	225	113	Ø6	M5
11~22kW	266	250	224	13	371	250	350.6	50.3	212	104	Ø6	M5
30~37kW	316	300	274	13	430	300	410	55	227	118.3	Ø6	M5
45~55kW	352	332	306	13	580	400	565	87	264	134	Ø9	M8
75kW	454	425	396	14.5	632	595	380	93	270	124	Ø9.5	M8
90~110kW	418.5	389.5	361	14.2	600	559	370	80	338	150	Ø10	M8
132~200kW	500	180	480	60	872	850	796	37	372	178.5	Ø11	M10

Product dimensions 2 (AC 3PH 660V input)

Product dimensions 3 (AC 3PH 220V input)

Product model	Outline dimensions W×H×D (mm)	Package dimensions W×H×D (mm)
GD350-01H-022G-6	270×557×325	659×378×423
GD350-01H-030G-6		
GD350-01H-037G-6		
GD350-01H-045G-6		
GD350-01H-055G-6	325×682×365	784×433×468
GD350-01H-075G-6		
GD350-01H-090G-6		
GD350-01H-110G-6		
GD350-01H-132G-6		
GD350-01H-160G-6	500×872×360	970×630×565
GD350-01H-185G-6		
GD350-01H-200G-6		
GD350-01H-220G-6		
GD350-01H-250G-6	680×960×380	1086×826×595
GD350-01H-280G-6		
GD350-01H-315G-6		
GD350-01H-355G-6		
GD350-01H-400G-6		
GD350-01H-450G-6	620×1700×560	1850×840×820
GD350-01H-500G-6		
GD350-01H-560G-6		
GD350-01H-630G-6		

Product model	Outline dimensions W×H×D (mm)
GD350-01H-3R7G-2	Same as GD350-01H-7R5G-4
GD350-01H-5R5G-2	Same as GD350-01H-011G-4
GD350-01H-7R5G-2	Same as GD350-01H-015G-4-L1
GD350-01H-011G-2	Same as GD350-01H-022G-4-L1
GD350-01H-015G-2	Same as GD350-01H-030G-4-L1
GD350-01H-018G-2	Same as GD350-01H-037G-4-L1
GD350-01H-022G-2	Same as GD350-01H-045G-4-L1
GD350-01H-030G-2	Same as GD350-01H-055G-4-L1
GD350-01H-037G-2	Same as GD350-01H-075G-4-L1
GD350-01H-045G-2	Same as GD350-01H-090G-4-L1
GD350-01H-055G-2	Same as GD350-01H-110G-4-L1
GD350-01H-075G-2	Same as GD350-01H-132G-4
GD350-01H-090G-2	Same as GD350-01H-185G-4
GD350-01H-110G-2	Same as GD350-01H-200G-4
GD350-01H-132G-2	Same as GD350-01H-250G-4
GD350-01H-160G-2	Same as GD350-01H-280G-4
GD350-01H-185G-2	Same as GD350-01H-355G-4
GD350-01H-200G-2	Same as GD350-01H-400G-4
GD350-01H-220G-2	Same as GD350-01H-450G-4
GD350-01H-250G-2	Same as GD350-01H-500G-4

Accessory selection >>>

HMI



Product series	Ordering code	Model	E Port	Serial port	Main functions and technical parameters
VS-Q series	11026-00025	VS-043QE	-	2	4.3 inch, 480×272, 24-bit color, 2 serial ports; RoHS
VS-Q series	11026-00022	VS-070QE	-	3	7 inch, 800×480, 24-bit color, 3 serial ports; RoHS
VS-Q series	11026-00023	VS-070QS	1	3	7 inch, 800×480, 24-bit color, 3 serial ports, 1 Ethernet port; RoHS
VS-Q series	11026-00029	VS-070QS-G	1	3	7 inch, 1024×600, 24-bit color, 3 serial ports, 1 Ethernet port, IoT expansion supported; RoHS
VS-Q series	11026-00024	VS-102QS	1	3	10.2 inch, 1024×600, 24-bit color, 3 serial ports, 1 Ethernet port; RoHS
VS-Q series	11026-00028	VS-102QS-G	1	3	10.2 inch, 1024×600, 24-bit color, 3 serial ports, 1 Ethernet port, IoT expansion supported; RoHS
VS-Q series	11026-00026	VS-156QS	1	2	15.6 inch, 1920×1080, 24-bit color, 2 serial ports, 1 Ethernet port; RoHS
VS-Q series	11095-00024	VS-Q-4G	0	0	4G module that supports China Mobile, China Unicom, and China Telecom networks (full coverage) and must be used with an IoT HMI.
VS-Q series	11095-00023	VS-Q-WIFI	0	0	Wi-Fi module that supports IEEE 802.11b/g/n frequency bands, and must be used with an IoT HMI.

*Cables need to be supplied by the user.

Reactor

VFD model	Input reactor	DC reactor
GD350-01H-7R5G-4	GDL-ACL0025-4CU	-
GD350-01H-011G-4	GDL-ACL0035-4AL	-
GD350-01H-015G-4-L1	GDL-ACL0040-4AL	Standard configuration
GD350-01H-018G-4-L1	GDL-ACL0051-4AL	Standard configuration
GD350-01H-022G-4-L1	GDL-ACL0051-4AL	Standard configuration
GD350-01H-030G-4-L1	GDL-ACL0070-4AL	Standard configuration
GD350-01H-037G-4-L1	GDL-ACL0090-4AL	Standard configuration
GD350-01H-045G-4-L1	GDL-ACL0110-4AL	Standard configuration
GD350-01H-055G-4-L1	GDL-ACL0150-4AL	Standard configuration
GD350-01H-075G-4-L1	GDL-ACL0150-4AL	Standard configuration
GD350-01H-090G-4-L1	GDL-ACL0220-4AL	Standard configuration
GD350-01H-110G-4-L1	GDL-ACL0220-4AL	Standard configuration
GD350-01H-132G-4	GDL-ACL0265-4AL	GDL-DCL0300-4AL
GD350-01H-160G-4	GDL-ACL0330-4AL	GDL-DCL0365-4AL
GD350-01H-185G-4	GDL-ACL0390-4AL	GDL-DCL0455-4AL
GD350-01H-200G-4	GDL-ACL0390-4AL	GDL-DCL0455-4AL
GD350-01H-220G-4	GDL-ACL0450-4AL	GDL-DCL0505-4AL
GD350-01H-250G-4	GDL-ACL0500-4AL	GDL-DCL0550-4AL
GD350-01H-280G-4	GDL-ACL0500-4AL	GDL-DCL0675-4AL
GD350-01H-315G-4	GDL-ACL0580-4AL	GDL-DCL0675-4AL
GD350-01H-355G-4	Standard configuration	GDL-DCL0810-4AL
GD350-01H-400G-4	Standard configuration	GDL-DCL0810-4AL
GD350-01H-450G-4	Standard configuration	GDL-DCL1000-4AL
GD350-01H-500G-4	Standard configuration	GDL-DCL1000-4AL

*The AC reactor with high carrier frequency output needs to be customized based on motor parameters.

Your Trusted Industry Automation Solution Provider

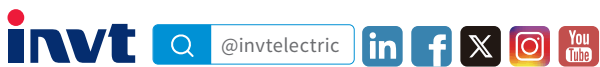
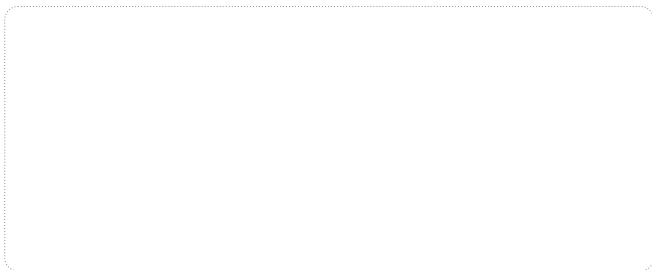

E-mail: overseas@invt.com.cn Website: www.invt.com

SHENZHEN INVT ELECTRIC CO.,LTD. INVT Guangming Technology Building, Songbai Road, Matian, Guangming District, Shenzhen, China

Industrial Automation: • HMI • PLC • VFD • Servo System • Elevator Intelligent Control System

Electric Power: • UPS • DCIM • Solar Inverter • New Energy Vehicle Powertrain System
• New Energy Vehicle Charging System • New Energy Vehicle Motor

INVT Copyright.
Information may be subject to change without notice during product improving.

66003-00376 202603(V2.0)